

[Home](#) ■ [Products](#) ■ [Grit Separation and Treatment](#) ■ [Complete Plants](#) ■
[HUBER Complete Plant Hydro Duct ROTAMAT® Ro5 HD](#)

HUBER Complete Plant Hydro Duct ROTAMAT® Ro5 HD



Complete Plant with Hydro Duct

- Well-proven mechanical preliminary treatment equipment
- High grit separation efficiency
- Optional separate grease chamber with grease removal
- Compact, space-saving unit

The Ro 5HD Complete Plant combines the benefits of both aerated and unaerated grit traps by using a high-performance grit trap with a small overall plan area. The wastewater flows firstly through an inlet screen that retains, washes, compacts and dewateres the solids contained within the flow.

The screened wastewater passes into an aerated grit trap that reduces the settlement of organics within the flow by the action of an aeration system within the grit trap. Grease along with other greasy material is collected in a separate integrated grease trap chamber from where the grease is automatically discharged by a well-proven paddle system.

The flow then enters a second unaerated upflow grit trap chamber which contains an integral hydro duct that ensures a directed flow approach from the bottom of the chamber with positive and uniform upflow distribution.

The flow velocity in the unaerated grit trap chamber is reduced to such an extent that very fine grit is easily and reliably separated.

Whilst the separated particles are removed from the grit trap by classifying screws, they are simultaneously being statically dewatered prior to being discharged into a container.

Benefits

BENEFITS OF OUR HUBER COMPLETE PLANT HYDRO DUCT ROTAMAT® RO5 HD

- Fully integrated screenings separation, washing and dewatering in one system
- Very high levels of grit separation
- Optional separate grease chamber with semiautomatic grease removal system
- Above-ground or underground installation
- Small footprint and space-saving compact design
- Integral emergency overflow in the grit trap
- Optional grit washing system
- Integral emergency by-pass

Downloads

 [Brochure: ROTAMAT® Complete Plant with Hydro-Duct Ro 5HD](#) [pdf, 190 KB]

Case Studies

- [New grease separation and removal system in our Hydro Duct grit traps](#)
- [Multifunctional Complete Plant installed on STP Ortenburg](#)

Design Sketch

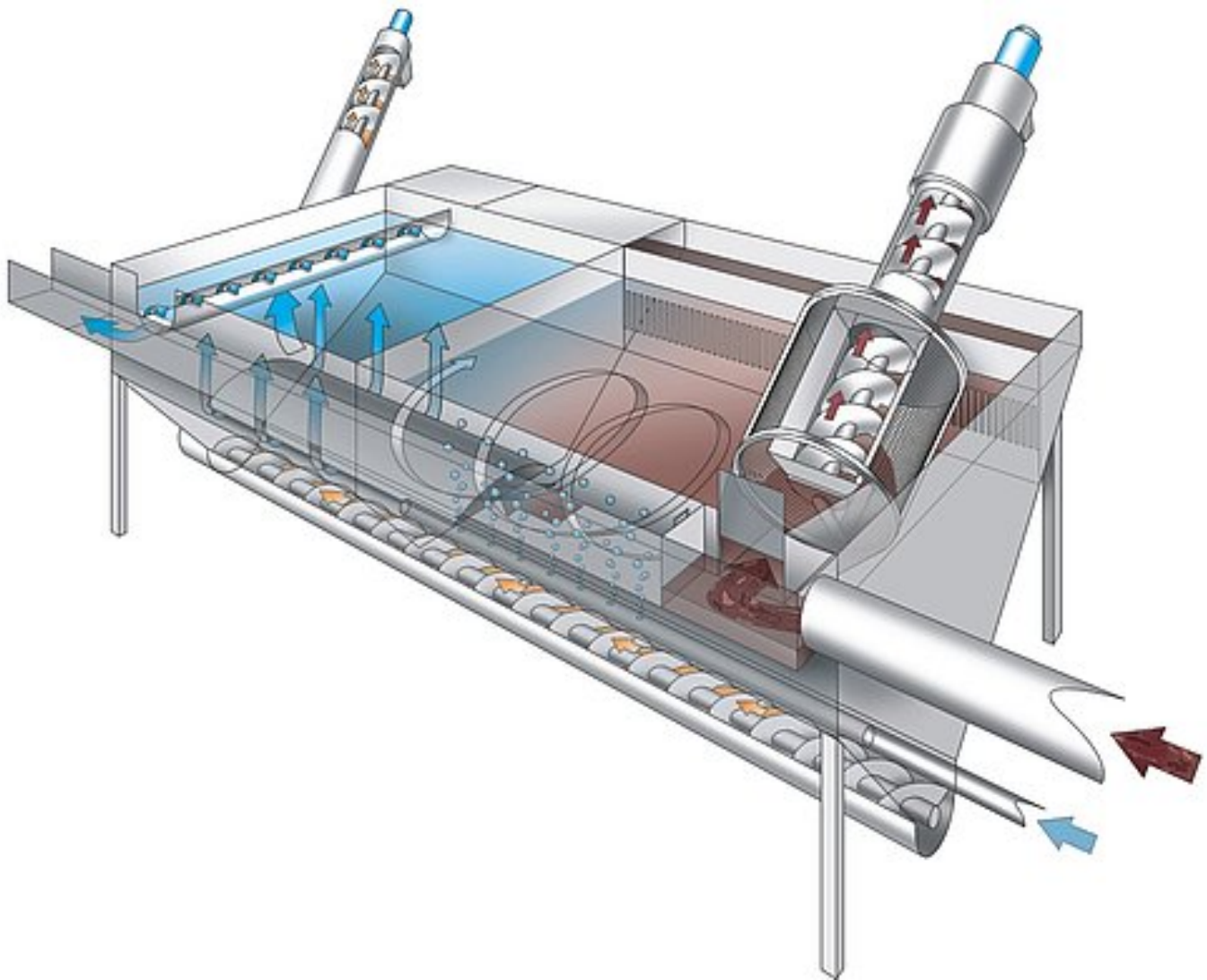

Media



More products of this group: Complete Plants

- [HUBER Complete Plant ROTAMAT® Ro5](#)
- [HUBER Coanda Complete Plant ROTAMAT® Ro5 C](#)

Huber Technology (Pty) Ltd
Company Reg. No.: 1992/006606/07

PO Box 9813
George, 6530
South Africa

Phone +27 44 874 4242
Fax +27 44 874 3658
huber@lantic.net
<http://www.hubersa.com>

A member of the HUBER Group